



Sistemi di verniciatura industriale  
automatismi ed impianti

# Automatic liquid mixing systems

*Automatic proportional mixing systems for multi-component paints are capable of mixing most epoxy and/or polyurethane paints. The systems can be powered at both low and high pressure, the potential margin of error in catalysis can be less than 1% depending on the models used. The two separate components arrive at the mixing chamber and only from the helical mixer onwards the paint is mixed. The enormous savings of paints which are automatically mixed only for the part necessary for spraying and when carrying out the painting phase. The predetermined quantity of solvent to be used for cleaning the system, without possible excesses by the operator. The savings on disposed paint given that there is no waste make the investment attractive. The timescale for recovering this investment is very short, given that the advantages are considerable and the operating cost is very low.*

*Mixes two-component paints easily and evenly*

## **EASY MAINTENANCE**

*Complete access to all products that require periodic assistance.*

- *Easy-to-service cartridge fluid valves*
- *Full access to all fluid components*
- *Externally mounted air filters*
- *Possibility to schedule maintenance notifications*

## **NO MORE EXPENSIVE REWORKS**

*Maintains the ratio within pre-defined tolerance limits, up to  $\pm 1\%$  in the version with dispenser. Out-of-ratio materials do not reach the product, thus eliminating costly rework.*

*Simple and flexible dosing*



**C.M. SPRAY S.R.L. Via T. Salsa, 10 z.i. 31030 CARBONERA (TV) ITALY**

Sede Legale : Via Lanzaghe, 32/D - 31057 SILEA (TV)

Tel. 0422.398768 - Fax 0422.398594 - [www.cmspray.it](http://www.cmspray.it) e-mail: [cmspray@cmspray.it](mailto:cmspray@cmspray.it)

P.IVA 02098100262 - R.E.A. Treviso n.0188412 - Reg. Imp. TV n. 02098100262 - Cap.soc. € 10.400,00 i.v.

# Automatic liquid mixing systems

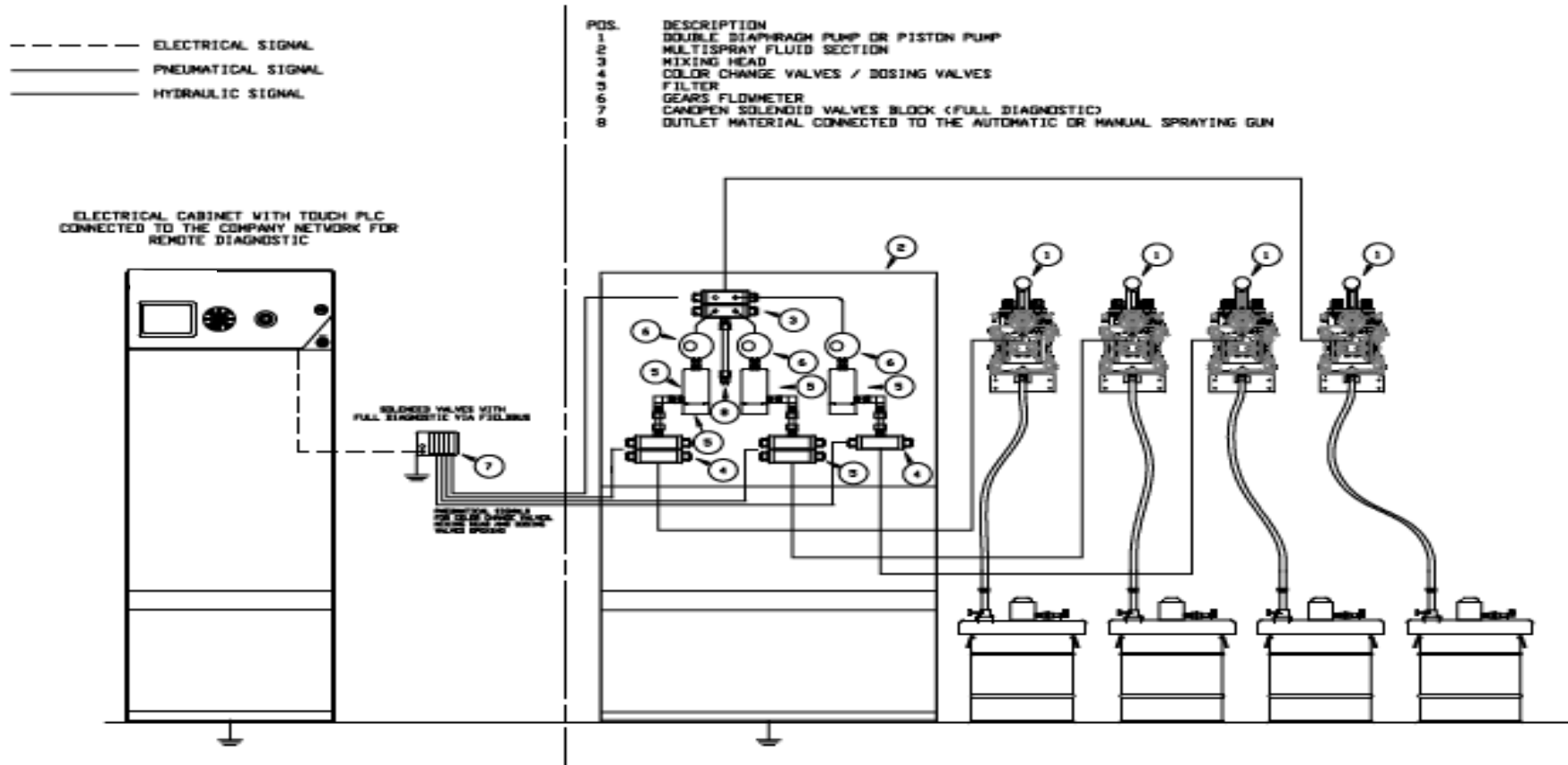

**C.M. SPRAY S.R.L. Via T. Salsa, 10 z.i. 31030 CARBONERA (TV) ITALY**

Sede Legale : Via Lanzaghe, 32/D - 31057 SILEA (TV)

Tel. 0422.398768 - Fax 0422.398594 - [www.cmspray.it](http://www.cmspray.it) e-mail: [cmspray@cmspray.it](mailto:cmspray@cmspray.it)

P.IVA 02098100262 - R.E.A. Treviso n.0188412 - Reg. Imp. TV n. 02098100262 - Cap.soc. € 10.400,00 i.v.



Sistemi di verniciatura industriale  
automatismi ed impianti

# Automatic liquid mixing systems

*The system based on gear-driven mass meters has reliable pumps, has SIMPLE operation and is always ready for use. The intuitive icon LCD display allows you to set, manage and monitor the system during its operation*

## EASY TO USE DISPLAY

- Simple operation options: standby, spray, purge and empty
- Allows you to view the mixing ratio, pot life and material flow rate
- Easy to change colors on measuring machines
- The screen is used to control costs and create environmental reports
- Programmable maintenance notifications: pump cycles, valve cycles and filter life

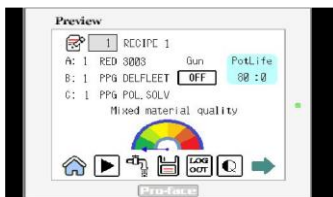

Elettrovalvole con diagnostica



Misuratori ingranaggi coriolis controllo corsa

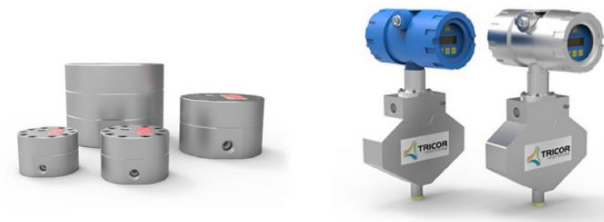

Valvole di cambio colore



2019/9/13



Testa di Miscelazione



**C.M. SPRAY S.R.L. Via T. Salsa, 10 z.i. 31030 CARBONERA (TV) ITALY**

Sede Legale : Via Lanzaghe, 32/D - 31057 SILEA (TV)

Tel. 0422.398768 - Fax 0422.398594 - [www.cmspray.it](http://www.cmspray.it) e-mail: [cmspray@cmspray.it](mailto:cmspray@cmspray.it)

P.IVA 02098100262 - R.E.A. Treviso n.0188412 - Reg. Imp. TV n. 02098100262 - Cap.soc. € 10.400,00 i.v.



Sistemi di verniciatura industriale  
automatismi ed impianti

# Automatic liquid mixing systems

DATI TECNICI	
Range rapporto di miscelazione:	0.1:1 - 50:1
Precisione di dosaggio	± 1%
Range di portata:	50 - 5000 cc/min
Pressione di esercizio:	fino a 250 bar
Massima pressione d'aria:	8 bar
Range viscosità:	20-10000 mPas
Ricette di lavoro:	fino a 100
N° max di componenti A:	fino a 30
N° max di componenti B:	fino a 10
N° max di componenti C:	fino a 5
N° max di componenti D:	fino a 5
N° max di lavaggi comp. A:	fino a 5
N° max di lavaggi comp. B:	fino a 5
Temperatura ambiente:	5-50 °C
Materiali a contatto:	303 - 304 - Carburo di Tungsteno - PTFE

OPZIONI / ACCESSORI
3k, 4k
App per gestione sistema tramite Smartphone / Tablet
Diagnosi da remoto
Display remoto / Comandi remoti per controllo a distanza
Dispositivo di prelievo separato dei componenti
Distributore per alimentazione indipendente n.2 pistole
Fino a due circuiti di miscelazione indipendenti controllati da un unico PLC
Flussostato o Pressostato pneumatico
Gun flush box
Interfaccia Robot con diversi bus di campo
Manometri prodotto
Misuratori Coriolis
Monitoraggio temperatura cabina
Monitoraggio temperatura sala pompe
Possibilità di collegare dispositivi di livello esterni (contatti puliti)
Raccolta dati tramite PC possibilità di interfaccia con software di logistica / MRP
Valvola proporzionale per regolazione automatica della portata*
Versione Atex

\*utilizzando un regolatore di pressione vernice a comando pneumatico.

**C.M. SPRAY S.R.L. Via T. Salsa, 10 z.i. 31030 CARBONERA (TV) ITALY**

Sede Legale : Via Lanzaghe, 32/D - 31057 SILEA (TV)

Tel. 0422.398768 - Fax 0422.398594 - [www.cmspray.it](http://www.cmspray.it) e-mail: [cmspray@cmspray.it](mailto:cmspray@cmspray.it)

P.IVA 02098100262 - R.E.A. Treviso n.0188412 - Reg. Imp. TV n. 02098100262 - Cap.soc. € 10.400,00 i.v.

# Automatic liquid mixing systems

Valvola automatica di cambio colore 250 bar, 1/4" Gas filetti

Due valvole indipendenti per ogni modulo

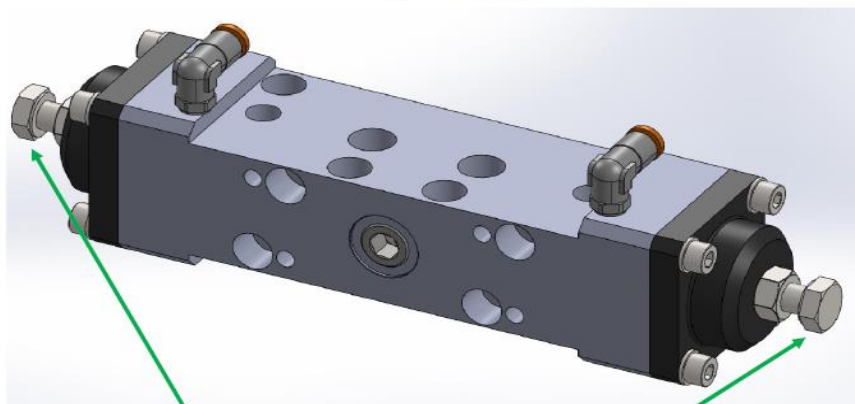

Corsa dell'ago regolabile  
 Quando si usano le valvole

Barriera con liquido per proteggere la guarnizione  
 Colore1 ingresso  
 Colore 2 ingresso

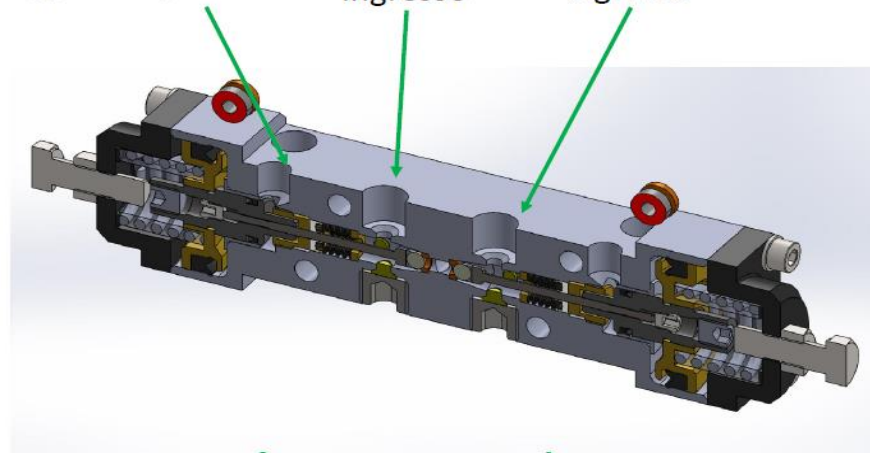

Colore 1  
 ricircolo

Colore 2  
 ricircolo

**C.M. SPRAY S.R.L. Via T. Salsa, 10 z.i. 31030 CARBONERA (TV) ITALY**

Sede Legale : Via Lanzaghe, 32/D - 31057 SILEA (TV)

Tel. 0422.398768 - Fax 0422.398594 - [www.cmspray.it](http://www.cmspray.it) e-mail: [cmspray@cmspray.it](mailto:cmspray@cmspray.it)

P.IVA 02098100262 - R.E.A. Treviso n.0188412 - Reg. Imp. TV n. 02098100262 - Cap.soc. € 10.400,00 i.v.



# Automatic liquid mixing systems

Testa di miscelazione 250 bar, 1/4" Gas fiatti

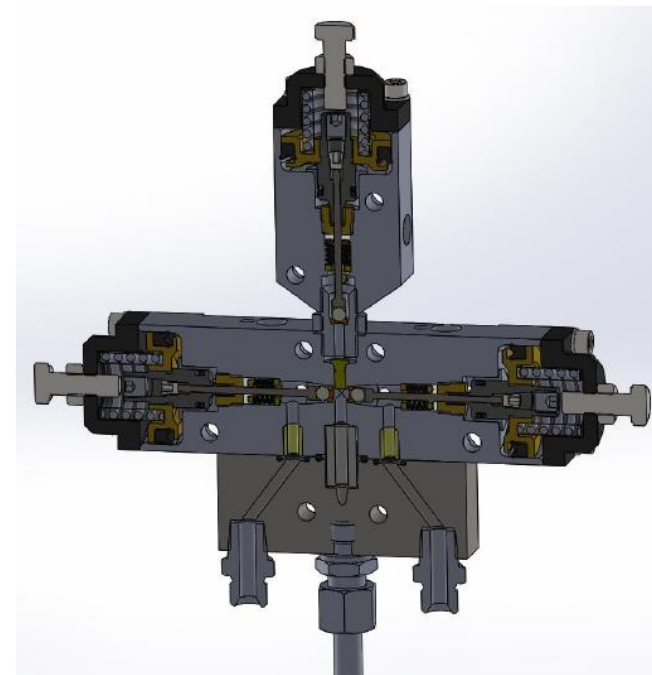
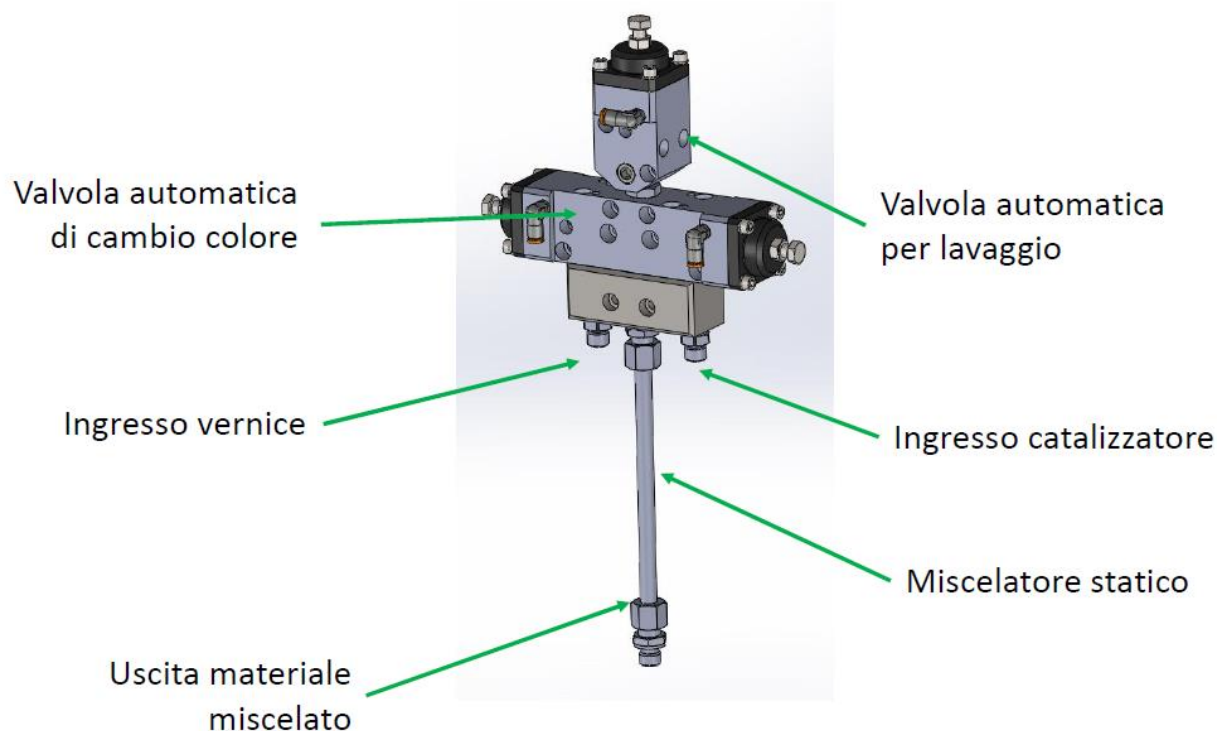

**C.M. SPRAY S.R.L. Via T. Salsa, 10 z.i. 31030 CARBONERA (TV) ITALY**

Sede Legale : Via Lanzaghe, 32/D - 31057 SILEA (TV)

Tel. 0422.398768 - Fax 0422.398594 - [www.cmspray.it](http://www.cmspray.it) e-mail: [cmspray@cmspray.it](mailto:cmspray@cmspray.it)

P.IVA 02098100262 - R.E.A. Treviso n.0188412 - Reg. Imp. TV n. 02098100262 - Cap.soc. € 10.400,00 i.v.



Sistemi di verniciatura industriale  
automatismi ed impianti

# Automatic liquid mixing systems

Gun Flush Box per rigenerazione e lavaggio automatico della pistola manuale

*Optional gun wash box for manual spray guns*

*They automatically empty the exact amount of solvent required, reducing waste and disposal costs.*

*Designed to handle most water-based and solvent-based materials.*

Cilindro pneumatico controllato dal PLC  
Per apertura grilletto pistola



Aggiustabile per diverse  
pistole con gli stessi elementi



**C.M. SPRAY S.R.L. Via T. Salsa, 10 z.i. 31030 CARBONERA (TV) ITALY**

Sede Legale : Via Lanzaghe, 32/D - 31057 SILEA (TV)

Tel. 0422.398768 - Fax 0422.398594 - [www.cmspray.it](http://www.cmspray.it) e-mail: [cmspray@cmspray.it](mailto:cmspray@cmspray.it)

P.IVA 02098100262 - R.E.A. Treviso n.0188412 - Reg. Imp. TV n. 02098100262 - Cap.soc. € 10.400,00 i.v.